

ALUMINUM
BODY & GRIPPER

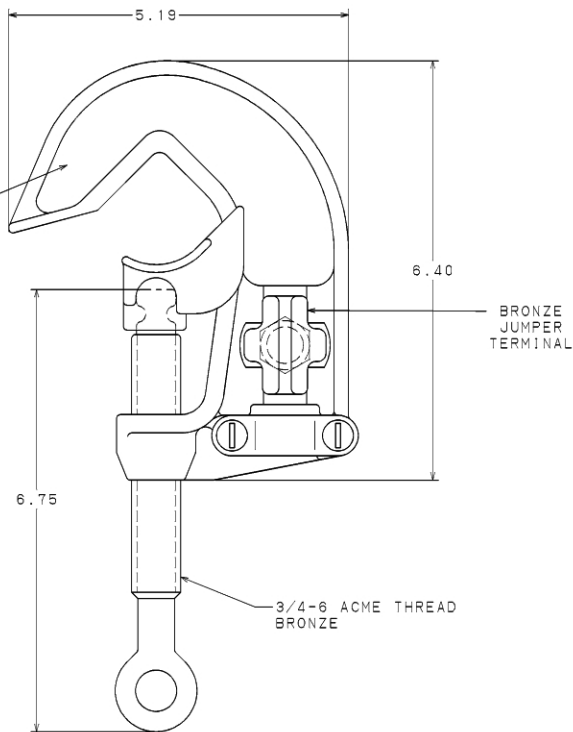

CATALOG NUMBER
G3605-1

ELECTRICAL RATINGS

CONTINUOUS CURRENT (AMPS)
FAULT CURRENT - 15 CYCLES (AMPS)
FAULT CURRENT - 30 CYCLES (AMPS)

400
43,000
30,000

MECHANICAL RATINGS

RECOMMENDED TORQUE (INCH-LBS.)
MAIN LINE RANGE - MAX.
MAIN LINE RANGE - MIN.
JUMPER RANGE - MAX.
JUMPER RANGE - MIN.
WEIGHT EACH
ASTM F855 GRADE

250
2" O.D. BUS
#8 SOL. CU. (.182")
4/0 GRD. CABLE W/ FERRULE
#2 GRD. CABLE W/ FERRULE
1-3/4 LBS. / 0.6 KG.
TYPE 1, CLASS A, GRADE 5

LATEST EC NO:	REV.	DATE	CHANGED BY	RESP ENGINEER
92092104	-	-----	---	KING
DRN BY: DATE TITLE: JONES 08-09-92 GROUNDING CLAMP				THIRD ANGLE PROJECTION 1:50 DUAL DIMENSIONS 1/8"=1" 3MM=10MM
				DWG NO: SA3605-1Q

CONFIDENTIAL: THIS DRAWING AND ITS CONTENTS ARE CONFIDENTIAL AND THE EXCLUSIVE PROPERTY OF HUBBELL. CHANGE, REVISION, OR REPRODUCTION, IN WHOLE OR IN PART, WITHOUT THE WRITTEN CONSENT OF HUBBELL IS PROHIBITED. UNPUBLISHED - ALL RIGHTS RESERVED UNDER THE COPYRIGHT LAWS OF THE UNITED STATES OF AMERICA. © 2000 HUBBELL/A. B. CHANCE.