

==NOTES==

1. H. D. GALVANIZE PER ASTM SPEC. A153-(LATEST REV.)
2. STENCIL ROD BEFORE GALV. AS SHOWN IN TABLE WITH 1/4" FLAT CHARACTERS. MUST BE READABLE AFTER GALV.

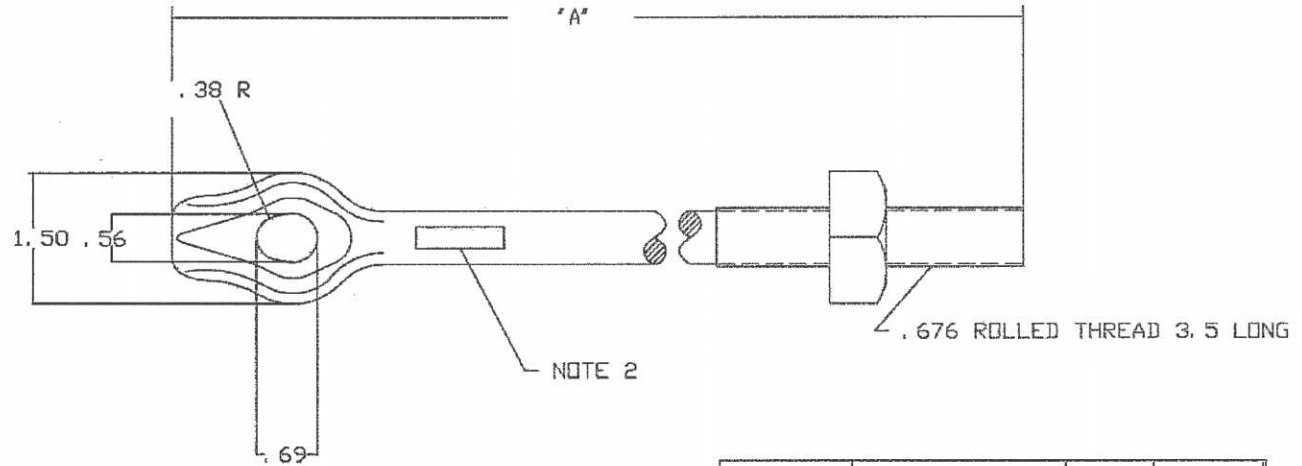
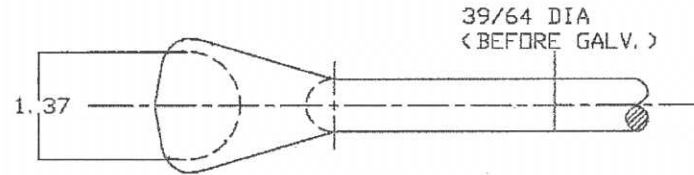

CAT. NO.	DESCRIPTION	"A"	STENCIL
5315	THIMBLEYE ROD, TH' D	60.00	C-5/8-5
5316	THIMBLEYE ROD, TH' D	72.00	C-5/8-6
5317	THIMBLEYE ROD, TH' D	84.00	C-5/8-7
5318	THIMBLEYE ROD, TH' D	96.00	C-5/8-8
E100-0106	THIMBLEYE ROD, TH' D	84.00	C-5/8-7
T5316G	THIMBLEYE ROD, TH' D	72.00	G-5/8-6
T5317G	THIMBLEYE ROD, TH' D	84.00	G-5/8-7
T5318G	THIMBLEYE ROD, TH' D	96.00	G-5/8-8

<p>CHANCE TOLERANCE CHART SEE CHART FOR TOLERANCE CHART FOR ALL DIMENSIONS UNLESS OTHERWISE SPECIFIED</p> <p>CONFIDENTIAL: THIS DRAWING AND ITS CONTENTS ARE CONFIDENTIAL AND THE EXCLUSIVE PROPERTY OF HUBBELL POWER SYSTEMS. NO REPRODUCTION, DISTRIBUTION OR COPIES MAY BE MADE WITHOUT THE WRITTEN CONSENT OF HUBBELL POWER SYSTEMS. HUBBELL POWER SYSTEMS UNPUBLISHED ALL RIGHTS RESERVED UNDER THE COPYRIGHT LAWS.</p>	<p>HUBBELL POWER SYSTEMS</p>	
	<p>TITLE THREADED THIMBLEYE ROD - 5/8"</p>	
<p>SIZE DWG NO. C SA5315</p>	<p>QTY / PART / ASSY NO. SEE CHART</p>	<p>REV</p>
<p>DO NOT SCALE THIS DRAWING</p>	<p>DRN BY QUALS</p>	<p>DATE 05/12/98 SHEET 01 OF 01</p>