

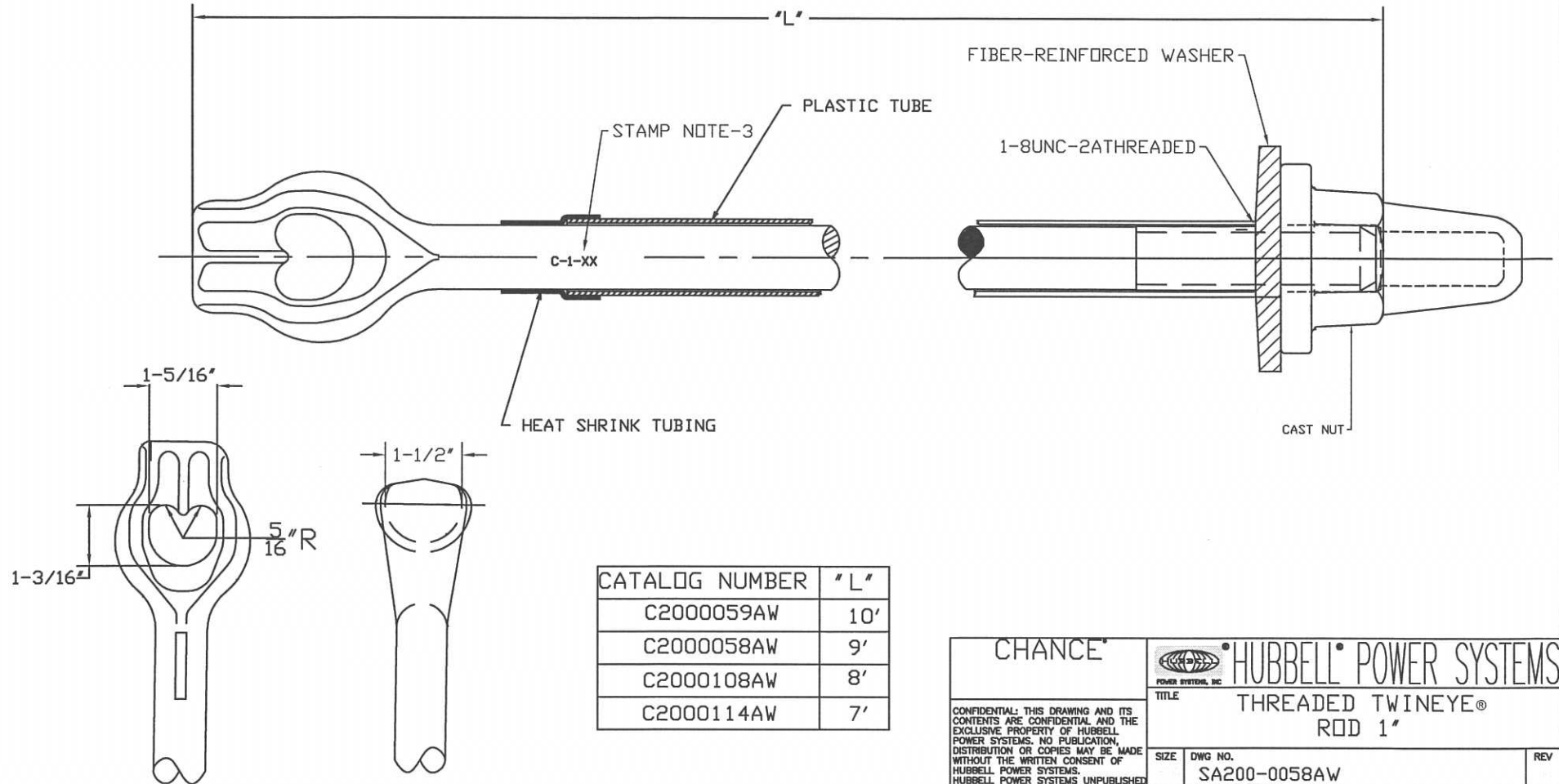

-NOTES-

1. MATERIAL: STEEL, HOT DIP GALVANIZED PER ASTM A153 (LATEST REVISION).
2. FINISH: BLACK ASPHALT COATING.
3. XX DENOTES THE LENGTH STAMP OF THE ROD. SEE "L" FOR LENGTHS.



CHANCE		 HUBBELL POWER SYSTEMS	
<small>CONFIDENTIAL: THIS DRAWING AND ITS CONTENTS ARE CONFIDENTIAL AND THE EXCLUSIVE PROPERTY OF HUBBELL POWER SYSTEMS. NO PUBLICATION, DISTRIBUTION OR COPIES MAY BE MADE WITHOUT THE WRITTEN CONSENT OF HUBBELL POWER SYSTEMS. HUBBELL POWER SYSTEMS UNPUBLISHED ALL RIGHTS RESERVED UNDER THE COPYRIGHT LAWS.</small>		TITLE THREADED TWINEYE® ROD 1"	
DO NOT SCALE THIS DRAWING	DRN BY MEB	DATE 11-16-15	SHEET
SIZE	DWG NO.	REV	
	SA200-0058AW		