

==NOTES==

1. SOCKET MADE OF DUCTILE IRON.
2. U-BOLT MADE OF C1045 STEEL.
3. SOCKET & U-BOLT HOT DIP GALVANIZE PER ASTM A153.

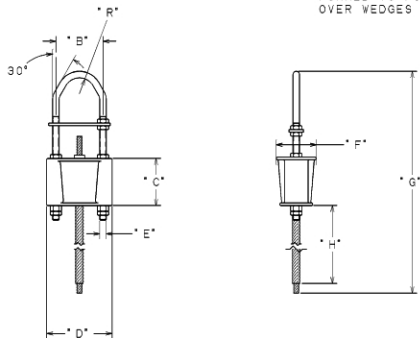
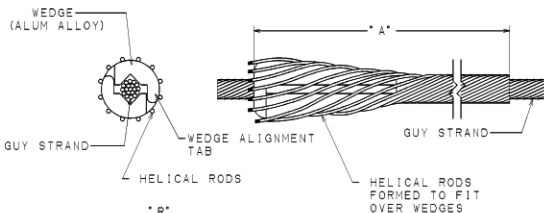

	A	B	C	D	E	F	G	H	R
7/8 GA-18	41	4-1/2	4-1/2	8-1/4	1	3-13/16	63	36-1/2	1-1/2
	1041.4	114.3	114.3	158.7	25.4	96.8	1600.2	927.1	38.1
15/16 GA-18	48	5-3/8	5	7-7/16	1-1/8	4-7/64	71	41	1-1/2
	1168.4	136.7	127	190	28.6	104.4	1803.4	1041.4	38.1
1 GA-18	50	5-3/8	5	7-7/16	1-1/8	4-7/64	73	45	1-1/2
	1270	136.7	127	190	28.6	104.4	1854.2	1143	38.1
899AVA-18	48	5-3/8	5	7-7/16	1-1/8	4-7/64	69	41	1-1/2
	1168.4	136.7	127	190	28.6	104.4	1752.6	1041.4	38.1
910AVA-18	48	5-3/8	5	7-7/16	1-1/8	4-7/64	69	41	1-1/2
	1168.4	136.7	127	190	28.6	104.4	1752.6	1041.4	38.1
1010AVA-18	50	5-3/8	5	7-7/16	1-1/8	4-7/64	73	45	1-1/2
	1270	136.7	127	190	28.6	104.4	1854.2	1143	38.1
1130AVA-18	54	5-3/4	5-1/2	8-3/16	1-1/4	4-15/16	78	48	2
	1371	146	140	208	32	124	1991.2	1219	51
805AVA-18	41	4-1/2	4-1/2	8-1/4	1	3-13/16	63	37	1-1/2
	1041	114	114	159	25	97	1600.2	940	38
717AVA-18	37	4	4	5-5/8	7/8	3-3/8	59	33	1-1/4
	940	102	102	143	22	86	1598.6	838	32
5/8 GA-18	35	3-1/2	3-1/2	4-7/8	3/4	3	56	31	1-1/4
	889	89	89	124	19	76	1422.4	767	32
3/4 GA-18	40	4	4	5-5/8	7/8	3-3/8	62	36	1-1/4
	1016	102	102	143	22	86	1576	914	32

LATEST EC NO: 87080518	REV: F	DATE 08-08-87	CHANGED BY: GUALLS	RESP ENGINEER HOYT
DWN BY: DATE TITLE MARTIN 08-08-87 ADJUST-A-GRIP, 18" ADJUST C			 THIRD ANGLE PROJECTION TWO EQUAL DIMENSIONS 1"=100, 10"=11 MILLIMETERS	
 STEEL STRIP		 S/N: NO:		 SA7/8GA-18

ALL RIGHTS RESERVED UNDER THE COPYRIGHT LAWS
 UNPUBLISHED
 © 2008 HUBBELL / A. B. CHANCE COMPANY
 NO REPLICATION, DISTRIBUTION OR
 THE EXCLUSIVE
 AND THE EXCLUSIVE
 PROPERTY OF HUBBELL / A. B. CHANCE COMPANY